

The T-Stick: Maintaining a 12 year-old Digital Musical Instrument

Alex Nieva
IDMIL, CIRMMT
McGill University
alex.nieva@mail.mcgill.ca

Johnty Wang
IDMIL, CIRMMT
McGill University
johnty.wang@mail.mcgill.ca

Joseph Malloch
Graphics and Experiential
Media (GEM) lab
Dalhousie University
joseph.malloch@dal.ca

Marcelo M. Wanderley
IDMIL, CIRMMT
McGill University
marcelo.wanderley@mcgill.ca

ABSTRACT

This paper presents the work to maintain several copies of the digital musical instrument (DMI) called the T-Stick in the hopes of extending their useful lifetime. The T-Sticks were originally conceived in 2006 and 20 copies have been built over the last 12 years. While they all preserve the original design concept, their evolution resulted in variations in choice of microcontrollers, and sensors. We worked with eight copies of the second and fourth generation T-Sticks to overcome issues related to the aging of components, changes in external software, lack of documentation, and in general, the problem of technical maintenance.

Author Keywords

DMI, electronic design, technological obsolescence.

CCS Concepts

•Hardware → Sensor applications and deployments;
•Human-centered computing → Sound-based input / output; •Applied computing → Performing arts;

1. INTRODUCTION

The digital era has accelerated the appearance of controllers and synthesizers to form a community around the concept of DMI use and design [2]. Despite the proliferation of creative new instruments, digital technology poses the inevitable problem of obsolescence. Deprecated and aging electronic components, communication protocols, operating systems updates, upgrades, and software compatibility all add to potential causes of DMI malfunction.

An interesting example on how to navigate the issues of rapid technological change is that of Michel Waisvisz's *The Hands* [3] which was used in performances for approximately 25 years. Unfortunately, not all DMI developers benefit from technical support similar to that provided by STEIM. Even though there is no intentional planned obsolescence in DMIs, it does still occur.

In order to tackle this problem of non-functioning instruments in research laboratories, we decided to work on one unique instrument that as of now is more than 12 years old: the T-Stick [1]. This DMI was conceived and developed at

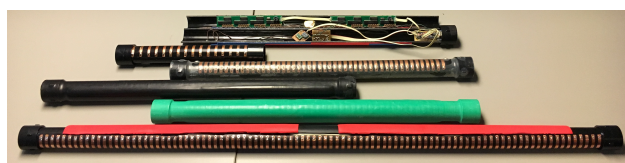

Figure 1: 6 out of the 8 T-Sticks currently operational at the IDMIL. Top to bottom: Soprano 4G (open), Sopranino, Sopranos (2GX, 2G, 2G), Tenor.

the Input Devices and Music Interaction Laboratory (IDMIL) at McGill University and has been used in music performances, research, and DMI design education in graduate seminars. It has been adopted by expert performers and composers as part of their musical practice including D. Andrew Stewart¹ (Soprano user) and Fernando Rocha² (Tenor user). It has appeared in dozens of public appearances in countries such as Canada, USA, Brazil, among others.³ The aim of this article is to report on the recent work done to keep the family of instruments operative.

2. THE T-STICK FAMILY OF DMIs

The T-Stick is a family of instruments since it was originally conceived in different sizes and weights that resemble a family of acoustic instruments. There are five models: Sopranino, Soprano, Alto, Tenor and Bass. There are differences in electronic design among the instrument generations but they maintain the same DMI design concept related to the gestures used to perform with the instrument.

The T-Stick was designed to have a robust physical interface usually made of ABS plumbing pipe with a diameter of 5cm and protected with shrinking tube (Fig. 1). It provides integral sensing and mapping which is intended to provide a logical and discoverable response to the player's actions. *Low entry fee* [4] was not prioritized; the instrument requires training and practice to reach a significant level of virtuosity⁴. For this paper we have worked with eight instruments that belong to three models of T-Sticks: the Sopranino, Soprano and Tenor versions. See Table 1.

¹See <https://blogs.ulethbridge.ca/andrewstewart/tstick/>

²See <http://www.fernandorocha.info/pt/publicacoes.html>.

³See <https://josephmalloch.wordpress.com/portfolio/tstick/>, for a partial list of performances.

⁴See [1] for further details on the instrument.



Licensed under a Creative Commons Attribution 4.0 International License (CC BY 4.0). Copyright remains with the author(s).

NIME'18, June 3-6, 2018, Blacksburg, Virginia, USA.

Table 1: Sensors in the T-Sticks used in this paper.

	Sopranino		Soprano		Tenor
	2G	2G	2GX	4G	2G
Capacitive strips	16	48	48	48	96
Analog Accelerometer	-	1	1	-	1
Digital Accelerometer	1	-	-	-	-
MARGS	-	-	-	1	-
Piezoelectric	1	1	1	1	1
FSR	-	-	-	-	2
Paper force sensor	1	1	1	1	-
IR	-	-	1	-	-
Air pressure sensor	-	-	1	-	-
Photoresistor	-	-	1	-	-

3. HARDWARE MAINTENANCE

The state of the instruments was divided in two groups: 5 were shrink-tubed without identified driver software and 3 were open in pieces. The goal of our hardware maintenance process was to ensure functional serial communication between the DMI and host computer. This would ensure the hardware was working properly and that we could continue onto revising the driver software. See process in Fig. 2.

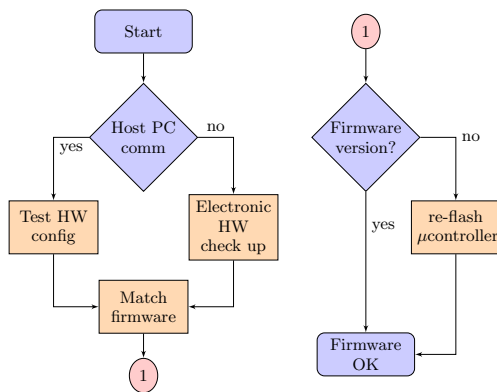

Figure 2: Flow diagram showing the hardware maintenance process for the T-Sticks.

Serial communication was tested for the first group with original archived driver software. 3 Sopranos 2G and the GX passed the process to figure out its internal configuration and match it with different versions of existing firmware also archived in the laboratory database. This testing was performed by probing the microcontroller EEPROM for information on connection pins and revision of elementary sensor data coming back from the DMI. For example, knowing that there was an accelerometer installed, the DMI would be tilted in different directions to determine the position of the sensor inside of the instrument. This was important since we could keep the instrument as it was with the shrinking tube in place. The Tenor allowed for communication but no sensor data was being sent so it had to be opened.

The Tenor and the second group of T-Sticks (Soprano 2G and 4G, and Sopranino) underwent electronic diagnostics and repair. Re-soldering, re-wiring, voltage supply and continuity tests were done in order to enable communication with the computer. If these repairs allowed for data transfer then the same process of probing was performed. On the other hand, even if the repairs did not allow for data transfer, an upgraded version of the firmware was re-flashed into the microcontroller (since now we had access to the internal connections of the instrument and firmware could be written for it).

Going through the process of repairing the instruments allowed us to inspect the hardware components. We cataloged all of them in detail and took note of the wiring of the instrument, and relevant information that now is part of the technical specifications of each DMI⁵.

4. SOFTWARE HOMOGENIZATION

The heart of the sensor data acquisition and control is based on the Arduino ecosystem. The original firmware was written in the IDE version 00xx which is no longer supported. Information on firmware version and date, as well as sensor organization and configuration of the T-Stick is saved in the microcontroller’s EEPROM. We have updated some of the firmware to work with IDE version 1.8.3 to re-flash instruments that were refurbished and allow for consistency among all of them. Each T-Stick model has specific firmware.

The instruments communicate with the host computer via a USB to serial IC adapter. In the host computer there is a driver patch developed in Max/MSP that implements serial communication with the microcontroller board, parses the data received and sends configuration data back to the microcontroller that can be written to EEPROM when needed. The data received in the host computer are then formatted with Open Sound Control (OSC) addresses for data processing and gesture extraction. All the communication is done in OSC format from this stage on.

Due to the nature of each T-Stick, each copy has a customized software driver so that all the sensor data is exposed in *libmapper*⁶, a software library to connect interactive media control systems. This did not prevent us from homogenizing the data flow process in all the patches and deliver the raw and processed signals in a structured form.

5. CONCLUSIONS

The fight for maintaining a rather old DMI allows for its availability for researchers, artists, and students. Facing this problem in the context of the T-Stick, showed us the importance of refining our decisions: how much should one change things, how much should we keep as is, having in mind that one of the most important things is to maintain the original concept of the instrument. Documenting and designing with community supported open-source electronic platforms aid in the maintenance process. Building multiple copies systematizes electronic design and leverages DMI craft expertise, especially if it is done as part of a pedagogical endeavor. As in traditional instrument lutherie, digital lutherie should be a balance of science and art.

6. REFERENCES

- [1] J. Malloch and M. M. Wanderley. The T-Stick : From musical interface to musical instrument. In *Proceedings of the International Conference on New Interfaces for Musical Expression*, pages 66–69, 2007.
- [2] E. R. Miranda and M. Wanderley. *New Digital Musical Instruments: Control And Interaction Beyond the Keyboard (Computer Music and Digital Audio Series)*. A-R Editions, Inc., Madison, WI, USA, 2006.
- [3] G. Torre, K. Andersen, and F. Baldé. The Hands: The making of a digital musical instrument. *Computer Music Journal*, 40(2):22–34, 2016.
- [4] D. Wessel and M. Wright. Problems and prospects for intimate control of computers. *Computer Music Journal*, 26:3:11–22, Fall 2002.

⁵http://idmil.org/projects/the_t-stick

⁶<http://libmapper.github.io/>